

N-Driver384

Product Specification v1.0

(vehicular type)



User Instructions



Precautions for safe use

This content is to ensure that the user uses the product properly to avoid danger or property damage. Before using this product, please read the instructions carefully and properly keep it for future reference.

As shown below, the precautions are divided into two parts, i.e., "warnings" and "cautions":

Warning: Ignoring a warning may result in death or serious injury.

Caution: Ignoring a caution may result in injury or property damage.

<p>Warning Instructions to ensure the users to avoid potential dangers may result in death or serious injury.</p>	<p>Caution Instructions to ensure the users to avoid potential dangers may result in injury or property damage.</p>



Warnings

- Install and use this product in strict accordance with all relevant national and local electrical safety regulations.
- Use power adapters supplied by legitimate manufacturers, power supply of the module: DC24V/1A.
- Do not connect multiple modules to a power adapter (overload of the adapter may result in excessive heat or fire).
- Power off the module during wiring, disassembly and other operations, do not allow live operation.
- Immediately power off the module off in the event of smoke, stench or noise during its use, and contact the distributor or service center to deal with related matters.

- If the equipment does not work properly, please contact the store where you purchased the equipment or the nearest service center. Do not disassemble or modify the equipment in any way. (We are not liable for any problems arising from unauthorized modification or repair).



Cautions

- Do not drop any object on the equipment or vigorously shake the equipment, and keep the equipment away from magnetic field interference. Avoid installing the equipment to a place where the surface vibrates or is subject to impact. (Ignoring this may damage the equipment).
- Do not use the equipment in environment with high temperature (higher than 70°C) or low temperature (lower than -40°C) or high humidity (higher than 95%).
- Do not expose the module to objects giving out bright light, such as sun, otherwise the module will be damaged.
- Do not place the equipment in a location under direct sunlight or a poorly ventilated location, or near heat source such as heater or heating (ignoring this may cause a fire hazard).
- Do not frequently power on/off the machine, turn it on at least 30 seconds after it is turned off, otherwise the module life will be affected.
- Do not hot swap the 50pin interface, which will cause damage to the module.
- Do not touch the surface coating of the module lens directly with your hand, or scratch the lens with a hard object, which may lead to blurred imaging, affecting image quality.
- Use sufficiently soft dry cloth or other alternatives to wipe the lens surface to clean the module. Do not use alkaline detergent.

● **Disclaimer**

Please ensure that you have read and fully understand the product instructions and the statement before using this product. You should install and use this product in strict accordance with the product instructions. If the user fails to strictly follow the instructions to install and use this product, it may bring great inconvenience to use, and may even cause property damage and personal injury. We assume no legal responsibility for any property damage and

personal injury arising from improper installation or improper use of the product.

● **Service Principle**

The series of products enjoy one-month replacement and one-year warranty. The specific service principle shall follow the provisions on the attached warranty card to perform warranty services. For products that have been discontinued, obsolescence or sold at a discount, the execution time shall follow written documents such as the notice of company.

● **Document Version**

Date	Version	changes	author
2020/11	V1.0	/	XU

This document is the property of Wuhan Global Sensor Technology Co. Ltd which reserves the final right to interpret it. Prior notice will not be given in case of any parameters updating due to product iteration.

1 Product Overview

1.1 Product description

N-Driver384 is a low-cost miniaturized uncooled vehicle infrared thermal imager with resolution of 400 * 300, which has the characteristics of low cost, high integration, shock resistance, vibration, etc.

N-Driver384 , as a vehicle gauge level infrared thermal imaging equipment, also has the following features:

- CVBS analog signal output, support pal and NTSC system;
- RS232 / can communication (optional). Can follows SAE J1939 protocol, and the communication rate is 500kbps / 250kbps (optional);
- The range of 300 meters is clear, which is 1.5 times of that of the high beam light. It can effectively improve the driver's field of vision, help to find the target in time, and improve the safety of driving;
- Detection distance: person (1.8m * 0.5m) \geq 150m; class B vehicle (2.3m * 2.3m) \geq 300m;
- Anti glare interference, all-weather application;
- Automatic heating function. When the window temperature is lower than 2 °C , the heater is automatically started; when the window temperature is higher than 7 °C , the heater is automatically turned off;
- 9 ~ 32V wide power input range, improving the reliability and stability of the whole machine;
- The protection grade of the whole machine is IP67;
- It has passed the China standard of passive infrared detection system for automobile;

The basic framework of the N-Driver384 is shown in Fig 1-1.

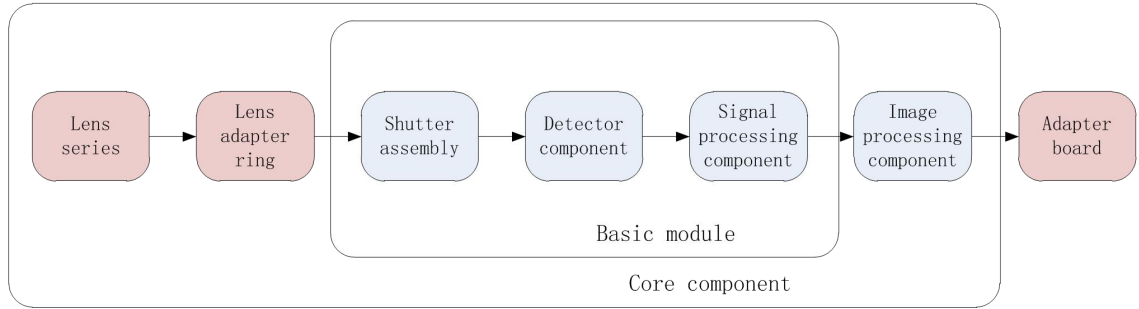

Fig1-1 N-Driver384 basic framework

The basic core module is the basic unit of the core, which mainly completes the basic imaging functions of the infrared thermal module, including lens system, the shutter assembly, the detector assembly, the image processing assembly and the power supply unit.

The shutter assembly uses an electromagnetic valve shutter, which has the advantages of good uniformity and short response time.

The detector assembly includes infrared detector, PCB and inter-board connector.

The signal processing component is used to realize basic signal processing circuits and time-series transmission channels.

The image processing component is mainly used to complete the image processing, analog video and digital video output, as well as power supply of the whole system.

1.2 Product configuration

1.2.1 Technical specification

➤ **Detector:** uncooled vanadium oxide, resolution:400X300

- Pixel pitch: 17um;
- Spectral: 8~14um;
- NETD: $\leq 50\text{mk}@F1.0@25^{\circ}\text{C}$

Output: CVBS, characteristic impedance 75 Ω . PAL video output, resolution 768X576@25Hz ; NTSC video output, resolution 720 X576@30Hz

➤ **communication:** RS232/CAN

- Can communication rate: 500kbps/250kbps, meeting SAE J1939 protocol
- Boot time: $\leq 8\text{S}$, supports boot screen customization
- Support image enlargement, flip, enhancement, pseudo color, etc

➤ **Physical properties**

- lens: 9.7mm, etc
- Dimension: 40mm*36mm*58mm(including lens)

➤ **Electrical properties**

Power supply: DC 9-32V.

Typical power consumption: $\leq 3.5\text{W}$ (heater does not work),
 $\leq 9\text{W}$ (heater is working)

➤ **External connecting cables**

External connecting cables include power interface (dc5.5 * 2.1 female), analog video (RCA lotus male) and serial communication interface (sm2.54-3p male). All connectors are vehicle specification level connectors.

➤ **Operating distance**

- Detection range: human(1.8m*0.5m) $\geq 150\text{m}$; B grade car(2.3m*2.3m) $\geq 300\text{m}$;

➤ **Environmental adaptability**

- Operating temperature: $-40^{\circ}\text{C} \sim +85^{\circ}\text{C}$
- Storage temperature: $-45^{\circ}\text{C} \sim +90^{\circ}\text{C}$

- Salt spray: GB/T 28046.4-2011, Grade IV
- Gravel impact: ISO 20567-1 standard. Iron shot size 4-5mm, shot peening dose 50g, test pressure 100KPA, lens no fragmentation. The image quality was normal after the experiment.
 - Shock: GB / T 28046.3-2011 standard, shock pulse form is half sine wave, performance grade A.
 - Impact: GB/T 28046.3-2011 standard. The impulse is in the form of half sine wave, and its performance grade A.
 - Vibration: GB/T 28046.3-2011 standard, performance grade A.
 - Flame retardant grade: GB8410 standard, grade B.
 - EMC:
 - ESD--- GB / T 19951-2019 [power off] contact discharge $\pm 8\text{Kv}$, air discharge $\pm 15\text{kV}$, grade 4; [power on] contact discharge $\pm 6\text{kV}$, air discharge $\pm 8\text{Kv}$, grade 3
 - Electrical transient immunity along power line--- ISO7637-2 standard.
 - P1: - 600 V, 1 ms, 50 Ohm; function level: C;
 - P2a: + 50V, 50 μs , 2 Ohm; function level: A;
 - P2b: + 20 V, 1 ms, 0.05 Ohm; function level: C;
 - P3a: P3a:-200V, 50 Ohm; function level: A;
 - P3b: +200 V, 50 Ohm; function level: A;
 - P4: -16V; function level: B;
 - Pulse 5b: US= 58V, 350 ms, 3.5 Ohm 5 pulses(The pulse interval is 1 minute); function level: C
 - Transient immunity of conductors other than power lines through capacitive and inductive coupling--- GB/T 21437.3-2012 standard, Level III.
 - BCI--- iso11452-4 2004, 75 Ma; 1 MHz – 400 MHz, performance level: B
 - RI--- ISO11452-2:200, 100 V/m; 400 MHz – 3GHz; performance level: B
- Protection degree: IP67

1.2.2 Optical configuration

The optical configuration of N-Driver is shown in Table1-1

Table1-1 Optical configuration

Focal length	Coating	Resolution	f/#	FOV (H×V, ±5%)	Weight (Module+Lens)
9.7mm(Athermal)	DLC	400X300@17um	1.0	37°x28°	150±3g

Note:

Lenses series of N-Driver384 supports front lens IP67. AR stands for anti-reflection film. DLC stand for Hardcarbon film.

1.3 Description of PC control software

Infrared Camera Controller enables online control of the N-Driver384 series.

The PC control software can be used in windows 7/8/10/XP and other operating systems.

Support Chinese/English language.

Typical baud rate of rs232:115200.

Communication rate of CAN network:500kbps/250kbsp(optional).

Refer to ICC software instructions for detailed software usage.

1.4 Unpacking

The standard configuration includes one N-Driver384 machine (including cable) and one product certificate.

The module shall be unpacked and used in environment with good electrostatic protection as it contains electrostatic sensitive electronic components. The module shall be put in an antistatic bag to avoid electrostatic damage.

The packing box shall be filled with foam material to prevent damage to the module

during transport.

2 Electrical interface instructions

2.1 Hardware Interface

The external interface of N-Drvier384 is cable interface, which can prevent disassembly. The protection degree is IP67. The cable interface mainly includes: power input, CVBS analog video output, RS232 serial port / can and other functions.

Dc5.5 * 2.1 female socket is used for power input.

RS232 serial port /CAN adopts sm2.54-3p(male).

CVBS analog video signal output adopts standard RCA lotus male head.

Table 2-1 definition of power input interface

Pin	Signal definition	Signal direction	Signal level	description
1	ACC24VIN	Power	24V	Power input
2	DGND	GND	0V	Power ground

Note:

The signal direction “O” stands for output, “I” stands for input and “NC” stands for not connect.

Table 2-2 definition of RS232 serial port

Pin	Signal definition	Signal direction	Signal level	description
1	DEBUG_RS232_TX/CAN_H	IO	RS232/CAN	RS232 TXD/CAN_H(optional)
2	DEBUG_RS232_RX/CAN_L	IO	RS232/CAN	RS232

				RXD/CAN_L(optional)
3	GND	GND	0V	

Note:

The signal direction “O” stands for output, “I” stands for input and “NC” stands for not connect.

Table 2-3 definition of CVBS analog video output interface

Pin	Signal definition	Signal direction	Signal level	description
1	CVBS_OUT	O	0~1V	Analog video output
2	CVBS_GND	GND	0V	Analog video ground

Note:

The signal direction “O” stands for output, “I” stands for input and “NC” stands for not connect.

The interface cable is as follows:

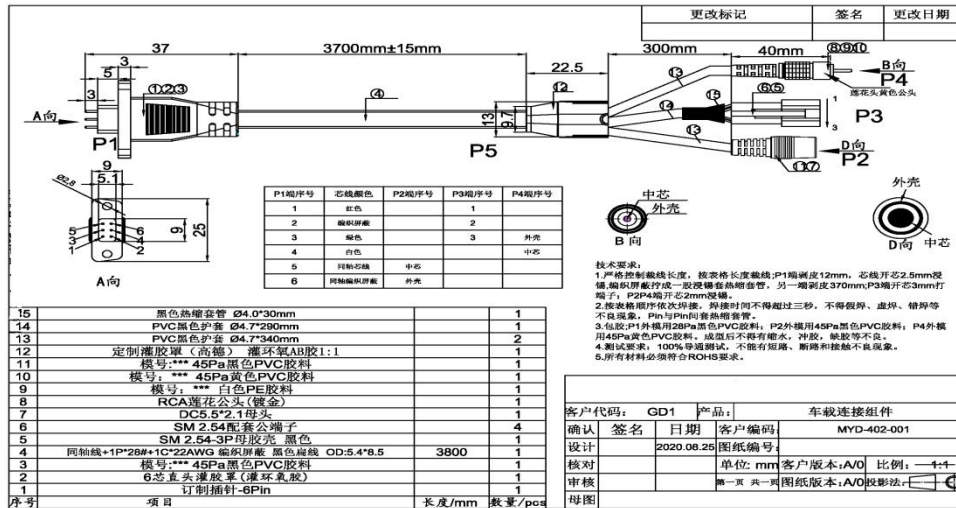

2.2 Input power requirements

Steady state power consumption of N-Driver384 device is no more than 3.5W. (@24V@23±3°C@25hz).

At the moment of shutter compensation, the transient power supplied by the core is less than 5W, and the maximum duration is less than 1s. When using the expansion board, the power supply voltage range of the device is DC 9v-32v. This voltage refers to the power receiving voltage at the device end. Please reserve the allowance in practical application. Insufficient power may cause the device work abnormally.

3 ICC control software

Please refer to ICC software user guide for this part.

4 FAQ

4.1 application demonstration



4.2 How to choose the correct serial number to connect

Answer: the solution is: After successful software installation, enable the device manager of the computer, and double-click "Port" to display the serial number to be connected by the module,  Silicon Labs CP210x USB to UART Bridge (COM3) . Select the appropriate serial number from the connection interface for use in connection. The typical connection baud rate is 115200.

ComNum	<input type="text" value="COM3"/>
	<ul style="list-style-type: none">COM1COM2COM3COM4
Baudrate	<input type="text" value="115200"/>
	<ul style="list-style-type: none">96001920038400115200

4.3 How to use digital port format

Answer:

A. There are two kinds of digital video format can be chosen, CMOS or BT.656.

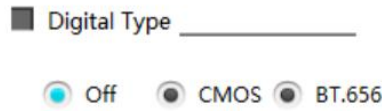

B. If you select the CMOS format, you need to select additional CMOS content and CMOS interface type to use normally.

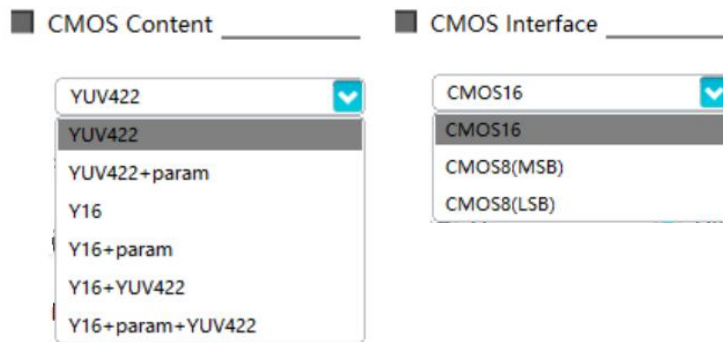

C. If the BT.656 format is selected, the core will automatically switch to the BT656 format data matching the corresponding frame frequency and video format;

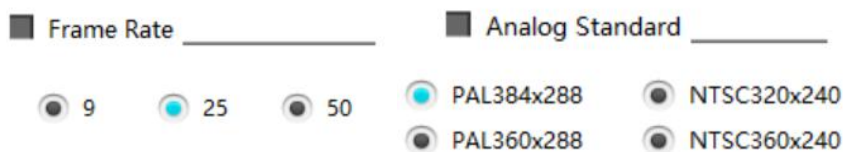

More BT.656 information can refer to the section “2.3.3 Description of BT.656 data”.

4.4 If the video capture card is installed, why real-time video display is unavailable when interface CMOS8 (MSB) or CMOS8 (LSB) is selected?

Answer: Except for interface CMOS16, the other two interfaces do not support real time video display.

4.5 Emissivity of common materials

Material	Emissivity	Material	Emissivity
Brass mirror	0.03	Bright paint(All colour)	0.90
Polished aluminum or aluminum foil	0.09	Stone	0.92
Pebble	0.28~0.04	Concrete	0.94
Gold-plated copper	0.30	Dark paint	0.95
Solder coated copper	0.35	Water	0.95~0.96
Wood	0.78	Smooth black paint	0.96~0.98
Paper	0.80~0.95	Bark	0.98
Bitumen	0.85	Ice	0.98
Sheet metal	0.88~0.90	Skin	0.98

5 Specification of Serial Communication Protocol

5.1 Overview

This chapter describes the applicable scope and format of serial protocol of PLUG module.

1. Serial port (typical baud rate of 115200) is applied to realize the control and communication of host computer of IR module.
2. Detailed protocol contents are defined.
3. The format of basic frame is as shown in Table 5-1.

Table 5-1 Serial port data format

Frame header		To start the communication frame, two bytes, specified data [55] [AA].		
Data length		Total number of bytes (including command word and data) of all command segments of the whole command frame, one byte;		
Command segment	Functional classification	Attribute of current menu.		
	Page	Page number of the current menu attribute.		
	Option	Option in current page, one byte; the highest order bit is used for marking the read-write.		
		bit[7]	bit[6:0]	Function
		1(RD)	80	Query current page
			xx	Read a register
0(WR)	xx	Write a register		
Command word	Value of the register, four bytes (32 bits)			
XOR checkout		The XOR checkout words of data length byte and all bytes of command segments;		

Frame end	To end the communication frame, one byte, specified data [F0]
-----------	---

5.2 Module connection protocol

If the software is started for the first time, select the COM port and baud rate and click CONNECT connection. The host sends a connection command, and the slave gives a response to the received query command after receiving the connection command. After receiving the response command, the host analyzes and displays the connection.

The working process as shown in Fig. 5-1.

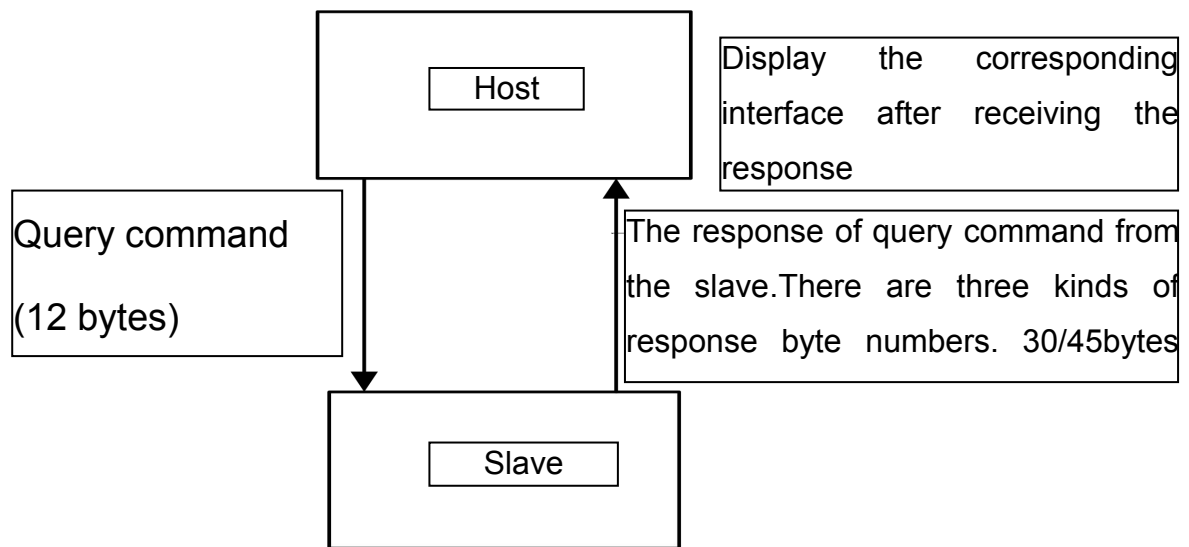

Fig. 5-1 The working process

5.2.1 Downlink protocol

There is only one type of command format of host computer, as shown in Table 5-2.

Table. 5-2 type of command format of host computer

Frame header	Length	Effective command words				Check bit	Frame end
		Functional category	Page	Option	Command word		
2 bytes	1 byte	1 byte	1 byte	1 byte	4 bytes	1 byte	1 byte
00-01	02	03	04	05	06~09	0A	0B
55 AA	07	00	00	0x/8x	00	XX	F0

The option part has 1 byte and the highest bit is used to identify the read-write operation.

The highest bit 1 represents read operation of host computer;

The highest bit 0 represents write operation of host computer;

The option of individual register begins with 0x01.

eg:

Query command: 55 AA + 07 + 00 + 00 + 80 + xxxxxxxx + XX + F0

It is used to inquire the register status of option 1 on the page 00 with function 00, in which, the command word part is invalid and any fixed value can be used.

The format of return command is same as that of query command. Place the query result 0x01020304 in the command word part, such as:

Query feedback command: 55 AA + 13+ 00 + 00 + xx..... + XX + F0

Write operation command: 55 AA + 07 + 00 + 00 + 01 + 01020304 + XX + F0

It is used to write 0x01020304 into the register of option 1 on the page 00 with function 00.

5.2.1.1 Control command

The control command format is as shown in Table 5-3.

Table 5-3 Control command format

Command word	Byte	Parameter description	Parameter type
Byte0	0x55	Frame header byte 1	Frame header
Byte1	0xAA	Frame header byte 2	
Byte2	0x07	The length is 7	Command length
Byte3	0x00	Status page	Functional classification

	0x01	Setup page	
	0x02	Video page	
	0x03	Application page	
	0x04	Temperature measurement page	
	0xA0	/	
Byte4	0x00	Page 1	Page
	0x01	Page 2	
	0x02	Page 3	
Byte5	0x01~0x07F	Option	ID number of command word
Byte6	0x00	Command high [31:24]	Command word
Byte7	0x00	Command low [23:16]	
Byte8	0x00	Command low [15:8]	
Byte9	0x00	Command low [7:0]	
Byte10	0XX	XOR checkout	

Byte11	0xF0	Frame end	Frame end
--------	------	-----------	-----------

5.2.1.1.1 Setup page

All operation commands of the function setting page: (55 AA 07 01 00 + option + command word (4 bytes) + XOR +F0). The command contents are specified as in Table 5-4.

Table 5-4 Operation commands of setup page

Option content	Option	Command word	Operation content	Operation command
Automatic compensation time (min)	0x01	00 00 00 xx	0~100	55 AA 07 01 00 01 00 00 00 xx XOR F0
Image freezing	0x02	00 0000 00	Not freezing	55 AA 07 01 00 02 00 00 00 00 04 F0
		00 0000 01	Freezing	55 AA 07 01 00 02 00 00 00 01 05 F0
Test Screen Switching	0x03	00 00 00 00	Real image	55 AA 07 01 00 03 00 00 00 00 05 F0
		00 00 00 01	Chess pattern	55 AA 07 01 00 03 00 00 00 01 04 F0
		00 00 00 02	Row gradients pattern	55 AA 07 01 00 03 00 00 00 02 07 F0
		00 00 00 03	Column gradients pattern	55 AA 07 01 00 03 00 00 00 03 06 F0
Save settings	0x04	00 00 00 01	Setting	55 AA 07 01 00 04 00 00 00 01 03 F0

Restore to factory default	0x05	00 00 00 01	Setting	55 AA 07 01 00 05 00 00 00 01 02 F0
Module restart	0x06	/	/	Not supported
temperature calibration	0x07	00 00 00 00	off	55 AA 07 01 00 07 00 00 00 00 01 F0
		00 00 00 01	on	55 AA 07 01 00 07 00 00 00 01 00 F0
Shutter control option	0x08	/	/	Not supported
Shutter manual control command	0x08	00 00 00 00	Shutter close	55 AA 07 A0 02 08 00 00 00 00 AD F0
		00 00 00 01	Shutter open	55 AA 07 A0 02 08 00 00 00 01 AC F0
Gain control (Observation type)	0x09	00 00 00 00	Standard	55 AA 07 01 00 09 00 00 00 00 0F F0
		00 00 00 01	Low noise	55 AA 07 01 00 09 00 00 00 01 0E F0

Note:

Timing compensation operation content 0 means timing compensation function is off, 1~100 means 1min~100min.

5.2.1.1.2 Video page

(1) Analog Video page

All operation command formats of the analog video page: (55 AA 07 02 00 + option + command word (4 byte) + XOR + F0). See Table 5-5 for details.

Table 5-5 Operation commands of analog video page

Option content	Option	Command word	Operation content	Operation command
Analog video switch	0x01	00 00 00 00	Off	55 AA 07 02 00 01 00 00 00 00 04 F0
		00 00 00 01	On	55 AA 07 02 00 01 00 00 00 01 05 F0
Video system switching	0x02	00 00 00 00	P:768x576	/ (This function is not supported)
		00 00 00 01	N:640x480	/ (This function is not supported)
		00 00 00 02	P:720x576	55 AA 07 02 00 02 00 00 00 02 05 F0
		00 00 00 03	N:720x480	55 AA 07 02 00 02 00 00 00 03 04 F0
Frame rate setting P-system : 50/25/9 N-system : 60/30/9	0x03	00 00 00 00	50/60Hz	55 AA 07 02 00 03 00 00 00 00 06 F0
		00 00 00 01	25/30Hz	55 AA 07 02 00 03 00 00 00 01 07 F0
		00 00 00 02	9Hz	55 AA 07 02 00 03 00 00 00 02 04 F0
Pseudo-color	0x04	00 00 00 00	White hot	55 AA 07 02 00 04 00 00 00 00 XOR F0
		00 00 00 01	Fulgurite	55 AA 07 02 00 04 00 00 00 01 XOR F0
		00 00 00 02	Iron Red	55 AA 07 02 00 04 00 00 00 02 XOR F0
		00 00 00 03	Hot Iron	55 AA 07 02 00 04 00 00 00 03 XOR F0
		00 00 00 04	Medical	55 AA 07 02 00 04 00 00 00 04 XOR F0
		00 00 00 05	Arctic	55 AA 07 02 00 04 00 00 00 05 XOR F0
		00 00 00 06	Rainbow 1	55 AA 07 02 00 04 00 00 00 06 XOR F0

		00 00 00 07	Rainbow 2	55 AA 07 02 00 04 00 00 00 07 XOR F0
		00 00 00 08	Tint	55 AA 07 02 00 04 00 00 00 08 XOR F0
		00 00 00 09	Black hot	55 AA 07 02 00 04 00 00 00 09 XOR F0
Mirror image	0x05	00 00 00 00	N/A	55 AA 07 02 00 05 00 00 00 00 00 F0
		00 00 00 01	Mirror X	55 AA 07 02 00 05 00 00 00 01 01 F0
		00 00 00 02	Mirror Y	55 AA 07 02 00 05 00 00 00 02 02 F0
		00 00 00 03	Mirror XY	55 AA 07 02 00 05 00 00 00 03 03 F0
EZOOM		00 00 00 xx	8~64(the effective value range 1 to 8)	55 AA 07 02 00 06 00 00 00 xx XOR F0
Coordinate X of the center of zoomed area	0x07	00 00 xxxx(MSB)	0~width-1	55 AA 07 02 00 07 00 00 xx xx XOR F0
Coordinate Y of the center of zoomed area	0x08	00 00 xxxx(MSB)	0~height-1	55 AA 07 02 00 08 00 00 xx xx XOR F0
Hotspot track switch	0x09	/	/	This page is not supported

Note:

EZOOM magnification of the operation content N need to be a multiple of 8, the actual effective value is N/8 times.

(2) Digital Video page

All operation command formats of the digital video page: (55 AA 07 02 01 + option + command word (4 byte) + XOR + F0) See Table 5-6 for details.

Table 5-6 Operation commands of digital video page

Option content	Option	Command word	Operation content	Operation command
External synchronization switch	0x01	00 00 00 00	Slave mode-Off	55 AA 07 02 01 01 00 00 00 00 05 F0
		00 00 00 01	Slave mode-On	55 AA 07 02 01 01 00 00 00 01 04 F0
		00 00 00 02	Master mode	55 AA 07 02 01 01 00 00 00 02 07 F0
Digital port type	0x02	00 00 00 00	Off	55 AA 07 02 01 02 00 00 00 00 06 F0
		00 00 00 01	BT.656	55 AA 07 02 01 02 00 00 00 01 07 F0
		00 00 00 02	CMOS	55 AA 07 02 01 02 00 00 00 02 04 F0
CMOS content selection	0x03	00 00 00 00	YUV422	55 AA 07 02 01 03 00 00 00 00 07 F0
		00 00 00 01	YUV422_ parameter line	55 AA 07 02 01 03 00 00 00 01 06 F0
		00 00 00 02	YUV16	55 AA 07 02 01 03 00 00 00 02 05 F0
		00 00 00 03	YUV16_ parameter line	55 AA 07 02 01 03 00 00 00 03 04 F0
		00 00 00 04	Y16_YUV422	55 AA 07 02 01 03 00 00 00 04 03 F0
		00 00 00 05	Y16_ parameter line_ YUV422	55 AA 07 02 01 03 00 00 00 05 02 F0
CMOS	0x04	00 00 00 00	CMOS16	55 AA 07 02 01 04 00 00 00 00 00 F0

interface type		00 00 00 01	CMOS8 (MSB first)	55 AA 07 02 01 04 00 00 00 01 01 F0
		00 00 00 02	CMOS8 (LSB first)	55 AA 07 02 01 04 00 00 00 02 02 F0
Frame rate setting P-system 50/25/9 N-system 60/30/9	0x05	00 00 00 00	50/60Hz	55 AA 07 02 01 05 00 00 00 00 01 F0
		00 00 00 01	25/30Hz	55 AA 07 02 01 05 00 00 00 01 00 F0
		00 00 00 02	9Hz	55 AA 07 02 01 05 00 00 00 02 03 F0
LVDS switch	0x06	00 00 00 00	Off	55 AA 07 02 01 06 00 00 00 00 02 F0
		00 00 00 01	On	55 AA 07 02 01 06 00 00 00 01 03 F0
Scene compensation	0x07	00 00 00 01	Compensation	55 AA 07 02 01 07 00 00 00 01 02 F0
Shutter compensation	0x08	00 00 00 01	Compensation	55 AA 07 02 01 08 00 00 00 01 0D F0
Digital port output clock phase	0x09	00 00 00 00	Rising edge alignment	55 AA 07 02 01 09 00 00 00 00 0D F0
		00 00 00 01	Fall edge alignment	55 AA 07 02 01 09 00 00 00 01 0C F0

(3) Algorithm setting page

All operation command formats of the algorithm setting page:

(55 AA 07 02 02 + option + command word (4 byte) + XOR+ F0).

See Table 5-7 for details.

Table 5-7 Operation commands of algorithm setting page

Option content	Option	Command word	Operation content	Operation command
----------------	--------	--------------	-------------------	-------------------

Time-domain filtering switch	0x01	00 00 00 00	Off	55 AA 07 02 02 01 00 00 00 00 06 F0
		00 00 00 01	On	55 AA 07 02 02 01 00 00 00 01 07 F0
Filtering strength	0x02	00 00 00 00	Level 0	55 AA 07 02 02 02 00 00 00 00 05 F0
		00 00 00 01	Level 1	55 AA 07 02 02 02 00 00 00 01 04 F0
		00 00 00 02	Level 2	55 AA 07 02 02 02 00 00 00 02 07 F0
		00 00 00 03	Level 3	55 AA 07 02 02 02 00 00 00 03 06 F0
		00 00 00 04	Level 4	55 AA 07 02 02 02 00 00 00 04 01 F0
		00 00 00 05	Level 5	55 AA 07 02 02 02 00 00 00 05 00 F0
		00 00 00 06	Level 6	55 AA 07 02 02 02 00 00 00 06 03 F0
		00 00 00 07	Level 7	55 AA 07 02 02 02 00 00 00 07 02 F0
		00 00 00 08	Level 8	55 AA 07 02 02 02 00 00 00 08 0D F0
		00 00 00 09	Level 9	55 AA 07 02 02 02 00 00 00 09 0C F0
Vertical strip removal switch	0x03	00 00 00 00	Off	55 AA 07 02 02 03 00 00 00 00 04 F0
		00 00 00 01	On	55 AA 07 02 02 03 00 00 00 01 05 F0
Vertical strip strength	0x04	/	/	Not supported
Sharpening switch	0x05	/	/	Not supported
Sharpening strength	0x06	/	/	Not supported
Dimming mode	0x07	00 0000 00	Linear	55 AA 07 02 02 07 00 00 00 00 00 F0
		00 0000 01	Platform	55 AA 07 02 02 07 00 00 00 01 01 F0
		00 0000 02	Hybrid	55 AA 07 02 02 07 00 00 00 02 02 F0

Proportion of upper throwing point	0x08	00 0000 xx	0~20	55 AA 07 02 02 08 00 00 00 xx XOR F0
Proportion of lower throwing point	0x09	00 0000 xx	0~20	55 AA 07 02 02 09 00 00 00 xx XOR F0
Brightness	0x0a	00 0000 xx	0~100	55 AA 07 02 02 0a 00 00 00 xx XOR F0
Contrast	0x0b	00 0000 xx	0~100	55 AA 07 02 02 0b 00 00 00 xx XOR F0
Hybrid dimming mapping range	0x0c	00 0000 xx	0~255	55 AA 07 02 02 0c 00 00 00 xx XOR F0
Y8 correction switch	0x0d	00 00 00 00	Off	55 AA 07 02 02 0d 00 00 00 00 0A F0
		00 0000 01	On	55 AA 07 02 02 0d 00 00 00 01 0B F0
Y8 correction expectation	0x0e	/	/	Not supported
Enhancement selection	0x0f	/	/	Not supported
IDE enhancement switch	0x10	00 00 00 00	Off	55 AA 07 02 02 10 00 00 00 00 17 F0
		00 00 00 01	On	55 AA 07 02 02 10 00 00 00 01 16 F0
IDE filtering level	0x11	00 0000 00	Level 0	55 AA 07 02 02 11 00 00 00 00 16 F0
		00 0000 01	Level 1	55 AA 07 02 02 11 00 00 00 01 17 F0
		00 0000 02	Level 2	55 AA 07 02 02 11 00 00 00 02 14 F0
		00 0000 03	Level 3	55 AA 07 02 02 11 00 00 00 03 15 F0
		00 0000 04	Level 4	55 AA 07 02 02 11 00 00 00 04 12 F0
IDE detail gain	0x12	00 00 00 xx	0~64	55 AA 07 02 02 12 00 00 00 xx XOR F0
LOG enhancement switch	0x13	/	/	Not supported

Y8 correction mode	0x14	00 00 00 00	Automatic	55 AA 07 02 02 14 00 00 00 00 13 F0
		00 00 00 01	Manual	55 AA 07 02 02 14 00 00 00 01 12 F0
Block histogram	0x15	00 00 00 00	Off	55 AA 07 02 02 15 00 00 00 00 12 F0
		00 00 00 01	On	55 AA 07 02 02 15 00 00 00 01 13 F0
Noise removal switch	0x16	00 00 00 00	Off	55 AA 07 02 02 16 00 00 00 00 11 F0
		00 00 00 01	On	55 AA 07 02 02 16 00 00 00 01 10 F0
Noise removal level	0x17	00 00 00 00	Level 0	55 AA 07 02 02 17 00 00 00 00 10 F0
		00 00 00 01	Level 1	55 AA 07 02 02 17 00 00 00 01 11 F0
		00 00 00 02	Level 2	55 AA 07 02 02 17 00 00 00 02 12 F0
		00 00 00 03	Level 3	55 AA 07 02 02 17 00 00 00 03 13 F0
		00 00 00 04	Level 4	55 AA 07 02 02 17 00 00 00 04 14 F0
		00 00 00 05	Level 5	55 AA 07 02 02 17 00 00 00 05 15 F0
		00 00 00 06	Level 6	55 AA 07 02 02 17 00 00 00 06 16 F0
		00 00 00 07	Level 7	55 AA 07 02 02 17 00 00 00 07 17 F0
		00 00 00 08	Level 8	55 AA 07 02 02 17 00 00 00 08 18 F0
		00 00 00 09	Level 9	55 A 07 02 02 17 00 00 00 09 19 F0

5.2.1.1.3 Advanced application page

1) Focusing page

All operation command formats of the focusing page: (55 AA 07 03 00 + option + command word (4 byte) + XOR + F0). See Table 5-8 for details.

Table 5-8 Operation commands of focusing page

Option content	Option	Command word	Operation content	Operation command
Lens selection (to be added or deducted based on product planning)	0x01	00 00 00 00	19mm	55 AA 07 03 00 01 00 00 00 00 05 F0
		00 00 00 01	25mm	55 AA 07 03 00 01 00 00 00 01 04 F0
		00 00 00 02		55 AA 07 03 00 01 00 00 00 02 07 F0
		00 00 00 03		55 AA 07 03 00 01 00 00 00 03 06 F0
		
Manual focusing speed	0x02	00 0000 xx	1~10	55 AA 07 03 00 02 00 00 00 xx XOR F0
Automatic statistics of automatic focusing	0x03	00 0000 xx	1~50	55 AA 07 03 00 03 00 00 00 xx XOR F0
MAX automatic focusing speed	0x04	00 0000 xx	1~10	55 AA 07 03 00 04 00 00 00 xx XOR F0
MIN automatic focusing speed	0x05	00 0000 xx	1~10	55 AA 07 03 00 05 00 00 00 xx XOR F0
Focus mode	0x06	00 00 00 00	Stop	55 AA 07 03 00 06 00 00 00 00 02 F0
		00 00 00 01	Manual far focus	55 AA 07 03 00 06 00 00 00 01 03 F0

		00 00 00 02	Manual near focus	55 AA 07 03 00 06 00 00 00 02 00 F0
		00 00 00 03	Automatic focusing	55 AA 07 03 00 06 00 00 00 03 01 F0

2) Defective pixel page

All operation command formats of the defective pixel page: (55 AA 07 03 01 + option + command word (4 byte) + XOR + F0). See Table 5-9 for details.

Table 5-9 Operation commands of defective pixel page

Option content	Option	Command word	Operation content	Operation command
Cross cursor switch	0x01	00 00 00 00	Off	55 AA 07 03 01 01 00 00 00 00 04 F0
		00 00 00 01	On	55 AA 07 03 01 01 00 00 00 01 05 F0
Cursor coordinate X	0x02	00 00 xxxx	0~width-1	55 AA 07 03 01 02 00 00 xx xx XOR F0
Cursor coordinate Y	0x03	00 00 xxxx	0~height-1	55 AA 07 03 01 03 00 00 xx xx XOR F0
Display of AD value				
Defective pixel	0x04	00 00 00 01	Defective	55 AA 07 03 01 04 00 00 00 01 00 F0

addition			pixel addition	
		00 00 00 02	Defective row addition	55 AA 07 03 01 04 00 00 00 02 03 F0
		00 00 00 03	Defective column addition	55 AA 07 03 01 04 00 00 00 02 03 F0
Defective pixel saving	0x05	00 00 00 01	Setting	55 AA 07 03 01 05 00 00 00 01 01 F0
Cursor color R	0x06	00 00 00 xx	Red component	55 AA 07 03 01 06 00 00 00 xx XOR F0
Cursor color G	0x07	00 00 00 xx	Green Component	55 AA 07 03 01 07 00 00 00 xx XOR F0
Cursor color B	0x08	00 00 00 xx	Blue component	55 AA 07 03 01 08 00 00 00 xx XOR F0

3) Menu function page

Not supported

4) Hots tracking page 1 (region analysis)

All operation command formats of the menu page: (55 AA 07 03 03 + option + command word (4 byte) + XOR+ F0). See Table 5-10 for details.

Table 5-10 Operation commands of menu function page

Option content	Option	Command word	Operation content	Operation command
Anaysis Mode	0x01	00 00 00 00	Anaysis Off	55 AA 07 03 03 01 00 00 00 00 06 F0
		00 00 00 01	Full screen anaysis	55 AA 07 03 03 01 00 00 00 01 07 F0
		00 00 00 02	Region 1	55 AA 07 03 03 01 00 00 00 02 04 F0
		00 00 00 03	Region 2	55 AA 07 03 03 01 00 00 00 03 05 F0
		00 00 00 04	Region 3	55 AA 07 03 03 01 00 00 00 04 02 F0
Region upper left corner coordinate X	0x02	00 00 xx xx	Region analysis (0~639)	55 AA 07 03 03 02 00 00 xx xx XOR F0
Region upper left corner coordinate Y	0x03	00 00 xx xx	Region analysis (0~511)	55 AA 07 03 03 03 00 00 xx xx XOR F0
Region width W	0x04	00 00 xx xx	Region analysis 1~640	55 AA 07 03 03 04 00 00 xx xx XOR F0
Region height H	0x05	00 00 xx xx	Region analysis 1~512	55 AA 07 03 03 05 00 00 xx xx XOR F0
Region frame color	0x06	00 00 00 xx	Component R(0~255)	55 AA 07 03 03 06 00 00 00 xx XOR F0

	0x07	00 00 00 xx	Component G(0~255)	55 AA 07 03 03 07 00 00 00 xx XOR F0
	0x08	00 00 00 xx	Component B(0~255)	55 AA 07 03 03 08 00 00 00 xx XOR F0
High temperature alarm switch	0x09	00 00 00 00	High temperature alarm off	55 AA 07 03 03 09 00 00 00 00 0E F0
		00 00 00 01	High temperature alarm on	55 AA 07 03 03 09 00 00 00 01 0F F0
High temperature alarm threshold	0x0a	00 00 xx xx	Note①	55 AA 07 03 03 0a 00 00 xx xx XOR F0

Note:

① Observation type setting range 0 to 65535, Thermography type setting range -50.0°C to 1000.0°C, magnify 10 times transmission.

5) Hotspot tracking page 2 (Hot tracking)

Hotspot tracking page all operation commands: 55 AA 07 03 04 + option + command word (4 byte) + XOR + F0

Fig5-11 Hotspot tracking page operating command

Option content	Option	Command word	Operation content	Operation command
cursor switch	0x01	00 00 00 00	The hottest spot cursor off	55 AA 07 03 04 01 00 00 00 00 01 F0
		00 00 00 01	The hottest spot cursor on	55 AA 07 03 04 01 00 00 00 01 00 F0
	0x02	00 00 00 00	The coldest spot cursor off	55 AA 07 03 04 02 00 00 00 00 02 F0
		00 00 00 01	The coldest spot cursor on	55 AA 07 03 04 02 00 00 00 01 03 F0

Hot spot tracking upper limit	0x03	00 00 xx xx	Note①	55 AA 07 03 04 03 00 00 xx xx XOR F0
Hotspot tracking lower limit	0x04	00 00 xx xx		55 AA 07 03 04 04 00 00 xx xx XOR F0
The hottest spot cursor color	0x05	00 00 00 xx	Component R(0~255)	55 AA 07 03 04 05 00 00 00 xx XOR F0
	0x06	00 00 00 xx	Component G(0~255)	55 AA 07 03 04 06 00 00 00 xx XOR F0
	0x07	00 00 00 xx	Component B(0~255)	55 AA 07 03 04 07 00 00 00 xx XOR F0
The coldest spot cursor color	0x08	00 00 00 xx	Component R(0~255)	55 AA 07 03 04 08 00 00 00 xx XOR F0
	0x09	00 00 00 xx	Component G(0~255)	55 AA 07 03 04 09 00 00 00 xx XOR F0
	0x0a	00 00 00 xx	Component B(0~255)	55 AA 07 03 04 0a 00 00 00 xx XOR F0

Note:

① Observation type setting range 0 to 65535, Thermography type setting range -50.0°C to 1000.0°C, magnify 10 times transmission.

6) Hotspot tracking page 3 (pseudo-color vision enhancement)

Pseudo-color vision enhancement all operation commands: 55 AA 07 03 04 + option + command word (4 byte) +XOR + F0.

Fig.5-12 Pseudo-color vision enhancement operation commands

Option content	Option	Command word	Operation content	Operation command
----------------	--------	--------------	-------------------	-------------------

Pseudo-color band switch (color bar)	0x01	00 00 00 00	Off	55 AA 07 03 05 01 00 00 00 00 00 F0
		00 00 00 01	On	55 AA 07 03 05 01 00 00 00 01 01 F0
Pseudo-color vision enhancement mode (level span)	0x02	00 00 00 00	Manual	55 AA 07 03 05 02 00 00 00 00 03 F0
		00 00 00 01	Semi-auto	55 AA 07 03 05 02 00 00 00 01 02 F0
		00 00 00 02	Automatic	55 AA 07 03 05 02 00 00 00 02 01 F0
Pseudo-color vision enhancement upper threshold	0x04	00 00 xx xx	Note①	55 AA 07 03 05 04 00 00 xx xx XOR F0
Pseudo-color vision enhancement Lower threshold	0x05	00 00 xx xx		55 AA 07 03 05 05 00 00 xx xx XOR F0
Isotherm switch (isotherm)	0x06	00 00 00 00	Off	55 AA 07 03 05 06 00 00 00 00 07 F0
		00 00 00 01	On	55 AA 07 03 05 06 00 00 00 01 06 F0
Isothermal model	0x07	00 00 00 00	Up and down Isothermal model	55 AA 07 03 05 07 00 00 00 00 06 F0
		00 00 00 01	Medium isotherm model	55 AA 07 03 05 07 00 00 00 01 07 F0
Upper limit of isotherm threshold	0x08	00 00 xx xx	Note①	55 AA 07 03 05 08 00 00 xx xx XOR F0
Lower limit of	0x09	00 00 xx xx		55 AA 07 03 05 09 00 00 xx xx XOR F0

isotherm threshold				
Isothermal pseudo-color band selection	0x0d	00 00 00 00	White heat	55 AA 07 03 05 0d 00 00 00 00 0C F0
		00 00 00 01	fulgurite	55 AA 07 03 05 0d 00 00 00 01 0D F0
		00 00 00 02	iron red	55 AA 07 03 05 0d 00 00 00 02 0E F0
		00 00 00 03	hot iron	55 AA 07 03 05 0d 00 00 00 03 0F F0
		00 00 00 04	medical treatment	55 AA 07 03 05 0d 00 00 00 04 08 F0
		00 00 00 05	arctic	55 AA 07 03 05 0d 00 00 00 05 09 F0
		00 00 00 06	Rainbow 1	55 AA 07 03 05 0d 00 00 00 06 0A F0
		00 00 00 07	Rainbow 2	55 AA 07 03 05 0d 00 00 00 07 0B F0
		00 00 00 08	Trace red	55 AA 07 03 05 0d 00 00 00 08 04 F0
		00 00 00 09	Black heat	55 AA 07 03 05 0d 00 00 00 09 05 F0

Note:

①Observation type setting range 0 to 65535, Thermography type setting range -50.0°C to 1000.0°C, magnify 10 times transmission.

5.2.1.1.4 Temperature measurement page

1) Parameter setting page

All operation commands of the function parameter setting page: (55 AA 07 04 00 + option + command word (4 bytes) + XOR + F0). The command contents are specified as shown in Table5-11.

Table 5-13 Operation commands of menu function page

Option	Option	Command	Operation	Operation command
--------	--------	---------	-----------	-------------------

content		word	content	
Distance setting	0x01	00 00 00 xx	0~100	55 AA 07 04 00 01 00 00 00 xx XOR F0
Emissivity setting	0x02	00 00 00 xx	0~100	55 AA 07 04 00 02 00 00 00 xx XOR F0
Measurement mode	0x03	00 00 00 00	Min + max temp.	55 AA 07 04 00 03 00 00 00 00 00 F0
		00 00 00 01	cursor spot+ max temp.	55 AA 07 04 00 03 00 00 00 01 01 F0
		00 00 00 02	min + cursor spot temp.	55 AA 07 04 00 03 00 00 00 02 02 F0
Temperature Show	0x04	00 00 00 00	degree Celsius	55 AA 07 04 00 04 00 00 00 00 07 F0
		00 00 00 01	degree Fahrenheit	55 AA 07 04 00 04 00 00 00 01 06 F0
		00 00 00 02	degree Kelvin	55 AA 07 04 00 04 00 00 00 02 05 F0
Factory reset	0x06	00 00 00 01	Setting	55 AA 07 04 00 06 00 00 00 01 04 F0
Reflected setting	0x07	00 00 xx xx	Setting	55 AA 07 04 00 07 00 00 xx xx XOR F0
Save settings	0x04	00 00 00 01	Setting	55 AA 07 01 00 04 00 00 00 01 03 F0
Humidity Save settings	0x08	00 00 00 xx	Setting	55 AA 07 04 00 08 00 00 00 xx XOR F0
Temperature	0x09	00 00 00 00	-20°C~150°C	55 AA 07 04 00 09 00 00 00 00 0A F0

measurement range		00 00 00 01	-20°C~550°C	55 AA 07 04 00 09 00 00 00 01 0B F0
----------------------	--	-------------	-------------	-------------------------------------

2) Thermography calibration page

Blackbody correction page

All operation commands of the function blackbody correction page: (55 AA 07 04 01 + option + command word (4 bytes) + XOR + F0) . See Table 5-14 for details.

Table5-14 Blackbody correction page operating command

Option content	Option	Command word	Operation content	Operation command
Area temperature switch	0x01	00 00 00 00	off	55 AA 07 04 02 01 00 00 00 00 00 F0
		00 00 00 01	on	55 AA 07 04 02 01 00 00 00 01 01 F0
The area selected command	0x02	00 00 00 01	Area one	55 AA 07 04 02 02 00 00 00 01 02 F0
		00 00 00 02	Area two	55 AA 07 04 02 02 00 00 00 02 01 F0
		00 00 00 03	Area three	55 AA 07 04 02 02 00 00 00 03 00 F0
the starting coordinate X	0x03	00 00 xx xx		55 AA 07 04 02 03 00 00 xx xx XOR F0
the starting coordinate Y	0x04	00 00 xx xx		55 AA 07 04 02 04 00 00 xx xx XOR F0
Region width	0x05	00 00 xx xx		55 AA 07 04 02 05 00 00 xx xx XOR F0
Region height	0x06	00 00 xx xx		55 AA 07 04 02 06 00 00 xx xx XOR F0
Area one temperature switch	0x07	00 00 00 00	off	55 AA 07 04 02 07 00 00 00 00 06 F0
		00 00 00 01	on	55 AA 07 04 02 07 00 00 00 01 07 F0
Area two	0x08	00 00 00 00	off	55 AA 07 04 02 08 00 00 00 00 09 F0

temperature switch		00 00 00 01	on	55 AA 07 04 02 08 00 00 00 01 08 F0
Area three temperature switch	0x09	00 00 00 00	off	55 AA 07 04 02 09 00 00 00 00 08 F0
		00 00 00 01	on	56 A 07 04 02 09 00 00 00 01 09 F0

5.2.1.2 Query command

The query commands are as shown in Table 5-15.

Table 5-15 Query commands

Command word	Byte	Parameter description	Parameter type
Byte0	0x55	Frame header byte 1	Frame header
Byte1	0xAA	Frame header byte 2	
Byte2	0x07	Length is 7	Command length
Byte3	0x00	Status page	Functional classification
	0x01	Setup page	
	0x02	Video page	
	0x03	Application page	
	0x04	Measurement page	
Byte4	0x00	Page 1	Page
	0x01	Page 2	
	0x02	Page 3	
Byte5	0x80	Page query code	
Byte6	0x00	0x00	Command word (command word is invalid at query, and the default is 0x00)
Byte7	0x00	0x00	
Byte8	0x00	0x00	
Byte9	0x00	0x00	
Byte10	0xFF	XOR checkout	Check bit
Byte11	0xF0	Frame end	Frame end

5.2.2 Uplink protocol

5.2.2.1 Handshake return

If the slave computer requires a certain time in responding to the control of host computer, the slave computer will return the operation completion command upon its completion of response operation, so that the host computer can continue operation. If no return command is received within the agreed time, the prompt of operation failed will be displayed.

The return command format is as shown in Table 5-16.

Table 5-16 Return command format

Frame header		Length	Option	Checksum	Frame end
2 bytes		1 byte	1 byte	1 byte	1 byte
00	01	02	03	04	05
55	AA	01	xx	XX	F0

1. Confirm the command receiving: 55 AA 01 00 01 F0.
2. Receiving error, resending of command is requested: 55 AA 01 01 00 F0.

See Table 5-17 for details of return command.

Table 5-17 Return commands

Command word	Byte	Parameter description	Parameter type
Byte0	0x55	Frame header byte 1	Frame header
Byte1	0xAA	Frame header byte 2	
Byte2	0x01	Length is 1	Command length
Byte3	0x00	Receiving confirmation	Receiving confirmation
	0x01	Receiving error, resending of command is requested	Receiving error, resending of command is requested
	0x02	Save settings	

	0x03	Restore factory settings	Return to current option number upon the completion of response
	0x04	Restart	
	0x05	Scene compensation	
	0x06	Shutter compensation	
	0x13	BL compensation	
	0x14	BH compensation	
	0x15	Calculate K	
	0x16	Save K	
	0x17	Load K	
	0x18	Load initial K	
	0x25	Upload BL	
	0x26	Upload BH	
	0x28	Upload NUC	
	0x29	Temperature parameter restored to factory default successfully	
	0x1A	Upload B0	
	0x1B	Upload B1	
	0x1C	Upload B2	
	0x1D	Upload B3	
	0x1E	Upload B4	
	0x1F	Upload B5	
	0x20	Upload B6	

	0x21	Upload B7	
	0x22	Upload B8	
	0x23	Upload B9	
	0x24	Upload K	
	0x25	Upload BL	
	0x26	Upload BH	
	0x27	Upload NUC	
	0x50	Upload PROGRAM	
	0x51	Upload FILTER	
	0x52	Upload RMS	
	0x53	Upload IDE	
	0x54	Upload IMAGE_RGB	
	0x55	Upload SINGLE_TMP	
	0x56	Upload START_IMAGE_RGB	
	0x57	Upload START_IMAGE	
	0x58	Upload MENU_RGB	
	0x59	Upload MENU	
	0x5A	Upload LOG	
	0x5B	Upload HF_CURSOR	
	0x5C	Upload ZSP_PROGRAM	
	0x34	Program upgrading	

	0x39	Defective pixel saving	
	0x40	Defective pixel addition	
	0x47	Low temperature blackbody collection completed	
	0x41	High temperature blackbody collection completed	
	0x42	Two point calibration successful	
	0x43	Two point calibration failed	
	0x44	Single point collection completed	
	0x45	Single point calibration successful	
	0x46	Single point calibration failed	
	0xA0	The “start to upload” mark of asic	
	0xA1	The “upgrading failed” mark of asic	
	0xA2	asic starts to flash	
Byte4	0xFF	XOR checkout	Check bit
Byte5	0xF0	Frame end	Frame end

5.2.2.2 Query return

After receiving the query command, the slave computer will respond and return all information of the queried page to the host computer. The response command format of lower computer is consistent with the return command format at query. Query returns are generally 24 bytes, and the thermography application page has special 30, 45 bytes.

The format of 24\30\45 bytes query return commands are as shown in Table5-18、5-19、

Table 5-18 Format of 24-bytes query return command

Frame header		Length	Valid command word			Check bit	Frame end
			Functional classification	Page	Option		
2Byte		1Byte	1Byte	1Byte	17Byte	1Byte	1Byte
00-01		02	03	04	05~21	22	23
55	AA	13	00	00	0000000...	XX	55

Table 5-19 Format of 30-bytes query return command

Frame header		Length	Valid command word			Check bit	Frame end
			Functional classification	Page	Option		
2Byte		1Byte	1Byte	1Byte	23Byte	1Byte	1Byte
00-01		02	03	04	05~27	28	29
55	AA	19	00	00	00 00000...	XX	F0

Table 5-20 Format of 45-bytes query return command

Frame header		Length	Valid command word			Frame header	Length
			Functional classification	Page	Option		
2Byte		1Byte	1Byte	1Byte	38Byte	1Byte	1Byte
00-01		02	03	04	05~42	43	44
55	AA	28	00	00	00 00000...	XX	F0

Details of 24\30\45 bytes query response command of slave computer are described in Table 5-21, 5-22, 5-23.

Table 5-21 24-bytes query return command

Command word	Byte	Parameter description	Parameter type
Byte0	0x55	Frame header byte 1	Frame header

Byte1	0xAA	Frame header byte 2	
Byte2	0x13	Length is 19	Command length
Byte3	0x00	Status page	Functional classification
	0x01	Setup page	
	0x02	Video page	
	0x03	Advance setting page	
	0x04	Measurement page	
Byte4	0x00	Page 1	
	0x01	Page 2	
	0x01	Page 3	
Byte5	0x00	Command of option 1	
Byte6	0x00	Command of option 2	
Byte7	0x00	Command of option 3	
Byte8	0x00	Command of option 4	
Byte9	0x00	Command of option 5	
Byte10	0x00	Command of option 6	
Byte11	0x00	Command of option 7	
Byte12	0x00	Command of option 8	
Byte13	0x00	Command of option 9	
Byte14	0x00	Command of option 10	
Byte15	0x00	Command of option 11	
Byte16	0x00	Command of option 12	

Byte17	0x00	Command of option 13	
Byte18	0x00	Command of option 14	
Byte19	0x00	Command of option 15	
Byte20	0x00	Command of option 16	
Byte21	0x00	Command of option 17	
Byte22	0xXX	XOR checkout	Check bit
Byte23	0xF0	Frame end	Frame end

Table5-22 30-bytes query return command

Command word	Byte	Parameter description	Parameter type
Byte0	0x55	Frame header byte 1	Frame header
Byte1	0xAA	Frame header byte 2	
Byte2	0x19	Length is 25	Command length
Byte3	0x00	Status page	Functional classification
	0x01	Setup page	
	0x02	Video page	
	0x03	Advance setting page	
	0x04	Measurement page	
Byte4	0x00	Page 1	Page
	0x01	Page 2	
	0x01	Page 3	
Byte5	0x00	Command of option 1	Command word

Byte6	0x00	Command of option 2	
Byte7	0x00	Command of option 3	
Byte8	0x00	Command of option 4	
Byte9	0x00	Command of option 5	
Byte10	0x00	Command of option 6	
Byte11	0x00	Command of option 7	
Byte12	0x00	Command of option 8	
Byte13	0x00	Command of option 9	
Byte14	0x00	Command of option 10	
Byte15	0x00	Command of option 11	
Byte16	0x00	Command of option 12	
Byte17	0x00	Command of option 13	
Byte18	0x00	Command of option 14	
Byte19	0x00	Command of option 15	
Byte20	0x00	Command of option 16	
Byte21	0x00	Command of option 17	
Byte22	0x00	Command of option 18	
Byte23	0x00	Command of option 19	
Byte24	0x00	Command of option 20	
Byte25	0x00	Command of option 21	
Byte26	0x00	Command of option 22	

Byte27	0x00	Command of option 23	
Byte28	0xXX	XOR checkout	Check bit
Byte29	0xF0	Frame end	Frame end

Table5-23 45-bytes query return command

Command word	Byte	Parameter description	Parameter type
Byte0	0x55	Frame header byte 1	Frame header
Byte1	0xAA	Frame header byte 2	
Byte2	0x28	Length is 40	Command length
Byte3	0x00	Status page	Functional classification
	0x01	Setup page	
	0x02	Video page	
	0x03	Advance setting page	
	0x04	Measurement page	
Byte4	0x00	Page 1	Page
	0x01	Page 2	
	0x02	Page 3	
Byte5	0x00	Command of option 1	Command word
Byte6	0x00	Command of option 2	
Byte7	0x00	Command of option 3	
Byte8	0x00	Command of option 4	
Byte9	0x00	Command of option 5	

Byte10	0x00	Command of option 6
Byte11	0x00	Command of option 7
Byte12	0x00	Command of option 8
Byte13	0x00	Command of option 9
Byte14	0x00	Command of option 10
Byte15	0x00	Command of option 11
Byte16	0x00	Command of option 12
Byte17	0x00	Command of option 13
Byte18	0x00	Command of option 14
Byte19	0x00	Command of option 15
Byte20	0x00	Command of option 16
Byte21	0x00	Command of option 17
Byte22	0x00	Command of option 18
Byte23	0x00	Command of option 19
Byte24	0x00	Command of option 20
Byte25	0x00	Command of option 21
Byte26	0x00	Command of option 22
Byte27	0x00	Command of option 23
Byte28	0x00	Command of option 24
Byte29	0x00	Command of option 25
Byte30	0x00	Command of option 26

Byte31	0x00	Command of option 27	
Byte32	0x00	Command of option 28	
Byte33	0x00	Command of option 29	
Byte34	0x00	Command of option 30	
Byte35	0x00	Command of option 31	
Byte36	0x00	Command of option 32	
Byte37	0x00	Command of option 33	
Byte38	0x00	Command of option 34	
Byte39	0x00	Command of option 35	
Byte40	0x00	Command of option 36	
Byte41	0x00	Command of option 37	
Byte42	0x00	Command of option 38	
Byte43	0xXX	XOR checkout	
Byte44	0xF0	Frame end	Frame end

5.2.2.2.1 Status page

Query response command contents of the status page are as shown in Table 5-24.

Table 5-24 Commands of status page

Command word	Byte	Parameter description	Parameter type
Byte0	0x55	Frame header byte 1	Frame header
Byte1	0xAA	Frame header byte 2	
Byte2	0x13	Length is 19	Command length

Byte3	0x00	Status page	Functional classification
Byte4	0x00	Page 1	Page number
Byte5	0x0A	PLUG612 Obervation type	ID number of module
	0x0B	PLUG612 Thermography type	
	Others	Reserved	
Byte6	0x00		ID number of communication object
Byte7	0x0D	Year (13)	Program version
Byte8	0x06	Month (06)	
Byte9	0x16	Day (22)	
Byte10	0x1E	Focal spot temperature high 8 bit	Focal plane temperature (precision: 0.01)
Byte11	0x00	Focal spot temperature low 8 bit	
Byte12	0x00	Video system	Video system
Byte13	0x08	640×512	ID number of resolution
	Others	Reserved	
Byte14	xx	Machine identification code [31:24]	
Byte15	xx	Machine identification code [23:16]	
Byte16	xx	Machine identification code[15:8]	

Byte17	xx	Machine identification code [7:0]	
Byte18~Byte21	0x00	Reserved	
Byte22	0xXX	Checksum	Check bit
Byte23	0xF0	Frame end	Frame end

5.2.2.2 Setup page

Query response command contents of the setup page are as shown in Table 5-25.

Table 5-25 Commands of setup page

Command word	Byte	Parameter description	Parameter type
Byte0	0x55	Frame header byte 1	Frame header
Byte1	0xAA	Frame header byte 2	
Byte2	0x13	Length is 19	Command length
Byte3	0x01	SETUP Status page	Functional classification
Byte4	0x00	Page 1	Page
Byte5	xx	Automatic compensation time (xxmin)	Command of option 1
Byte6	0x00	Image not freezing	Command of option 2

	0x01	Image freezing	
Byte7	0x00	Real-time image	Command of option 3
	0x01	Checker board pattern	
	0x02	Row gradients	
	0x03	Line gradients	
Byte8	0x00	The rising of temperature calibration switch off	
	0x01	The rising of temperature calibration switch on	
Byte9	0x00	Shutter control mode	Not supported
Byte10	0x00	Shutter close off	
	0x01	Shutter close on	
Byte11	0x00	Standard mode	Observation type
	0x01	Low noise mode	
Byte12~ Byte21	0x00	Reserved	

Byte22	0xXX	Checksum	Check bit
Byte23	0xF0	Frame end	Frame end

5.2.2.2.3 Video page

(1) Analog video page

Query response command contents of the analog video page are as shown in Table 5-26.

Table 5-26 Commands of analog video page

Command word	Byte	Parameter description	Parameter type
Byte0	0x55	Frame header byte 1	Frame header
Byte1	0xAA	Frame header byte 2	
Byte2	0x13	Length is 19	Command length
Byte3	0x02	Video page	Functional classification
Byte4	0x00	Analog video page (Page 1)	Page
Byte5	0x00	Analog video off	
	0x01	Analog video on	
Byte6	0x00	/	
	0x01	/	
	0x02	P-system 720x576	
	0x03	N-system 720x480	
Byte7 P-system 50/25/9	0x00	50/60Hz	

N-system 60/30/9	0x01	25/30Hz	
	0x02	9Hz	
Byte8	xx	Pseudo-color	
Byte9	0x00	No	
	0x01	Mirror image in X direction	
	0x02	Mirror image in Y direction	
	0x03	Mirror images in X and Y directions	
Byte10	xx	EZOOM zoom factor 8~64	
Byte11	xx	Coordinate X [15:0] of the center of zoomed area	
Byte12	xx	Coordinate X [7:0] of the center of zoomed area	
Byte13	xx	Coordinate Y [15:0] of the center of zoomed area	
Byte14	xx	Coordinate Y [7:0] of the center of zoomed area	
Byte15	0x00	Hot track switch	Not supported
Byte16~ Byte21	0x00	Reserved	
Byte22	0xXX	Checksum	Check bit
Byte23	0xF0	Frame end	Frame end

(2) Digital video page

Query response command contents of the digital video page are as shown in Table 5-27.

Table 5-27 Commands of digital video page

Command word	Byte	Parameter description	Parameter type
Byte0	0x55	Frame header byte 1	Frame header
Byte1	0xAA	Frame header byte 2	
Byte2	0x13	Length is 19	Command length
Byte3	0x02	Video page	Functional classification
Byte4	0x01	Digital video page (Page 2)	Page
Byte5	0x00	External synchronization enabling off	Command of option 1
	0x01	External synchronization enabling on	
Byte6	0x00	Digital port parallel off	Command of option 2
	0x01	Digital port BT.656	
	0x02	Digital port CMOS	
Byte7	0x00	YUV422	Command of option 3 Parallel output contents
	0x01	YUV422_ parameter line	
	0x02	YUV16	
	0x03	YUV16_ parameter line	
	0x04	Y16_YUV422	

	0x05	Y16_parameter line_ YUV422	
Byte8	0x00	CMOS16	Command of option 4 Parallel output interface type
	0x01	CMOS8(MSB first)	
	0x02	CMOS8(LSB first)	
Byte9	0x00	50/60Hz	Command of option 5
	0x01	25/30Hz	
	0x02	9Hz	
Byte10	0x00	Off	LVDS switch
	0x01	On	
Byte11	0x00	Rising edge alignment	Data lines are aligned with clocks
	0x01	Fall edge alignment	
Byte12~ Byte21	0x00	Reserved	
Byte22	0xXX	Checksum	Check bit
Byte23	0xF0	Frame end	Frame end

(3) Algorithm control page 1

Query response command contents of the algorithm control page 1 are as shown in Table 5-28.

Table 5-28 Algorithm control page 1

Command word	Byte	Parameter description	Parameter type
Byte0	0x55	Frame header byte 1	Frame header
Byte1	0xAA	Frame header byte 2	

Byte2	0x13	Length is 19	Command length
Byte3	0x02	Video page	Functional classification
Byte4	0x02	Digital video page (Page 3)	Page
Byte5	0x00	Time-domain filtering off	
	0x01	Time-domain filtering on	
Byte6	0x00	Level 0	Filtering strength
	0x01	Level 1	
	0x02	Level 2	
	0x03	Level 3	
	0x04	Level 4	
	0x05	Level 5	
	0x06	Level 6	
	0x07	Level 7	
	0x08	Level 8	
	0x09	Level 9	
Byte7	0x00	Vertical strip removal off	
	0x01	Vertical strip removal on	
Byte8	0x00	Vertical strip removal strength	Not supported
Byte9	0x00	Sharpening switch	Not supported
Byte10	0x00	Sharpening strength	Not supported

Byte11	0x00	Linear	Dimming mode
	0x01	Platform	
	0x02	Hybrid	
Byte12	xx	Proportion of upper throwing point 0~20	
Byte13	xx	Proportion of lower throwing point 0~20	
Byte14	xx	Brightness	
Byte15	xx	Contrast	
Byte16	xx	Hybrid dimming mapping	
Byte17~ Byte21	0x00	Reserved	
Byte22	0xXX	Checksum	Check bit
Byte23	0xF0	Frame end	Frame end

(4)

(5) Algorithm control page 2

Query response command contents of the algorithm control page 2 are as shown in Table 5-29.

Table 5-29 Algorithm control page 2

Command word	Byte	Parameter description	Parameter type
Byte0	0x55	Frame header byte 1	Frame header
Byte1	0xAA	Frame header byte 2	
Byte2	0x13	Length is 19	Command length

Byte3	0x02	Video page	Functional classification
Byte4	0x03	Digital video page (page 3)	Page
Byte5	0x00	Y8 correction off	
	0x01	Y8 correction on	
Byte6	0x00	Y8 correction expectation	Not supported
Byte7	0x00	Enhancement type	Not supported
Byte8	0x00	IDE enhancement off	
	0x01	IDE enhancement on	
Byte9	xx	IDE filtering level 0~4	
Byte10	xx	IDE detail gain 0~64	
Byte11	00	LOG enhancement switch	Not supported
Byte12	00	Y8 correction automatic mode	
	01	Y8 correction manual mode	
Byte13	00	Block histogram off	
	01	Block histogram on	
Byte14	00	Noise removal off	
	01	Noise removal on	
Byte15	0xXX	Noise removal level 0-9	
Byte16~Byte21	0x00	Reserved	

Byte22	0xXX	Checksum	Check bit
Byte23	0xF0	Frame end	Frame end

5.2.2.2.4 Advanced application page

(1) Focusing page

Query response command contents of the focusing page are as shown in Table 5-30.

Table 5-30 Commands of focusing page

Command word	Byte	Parameter description	Parameter type
Byte0	0x55	Frame header byte 1	Frame header
Byte1	0xAA	Frame header byte 2	
Byte2	0x13	Length is 19	Command length
Byte3	0x03	Application	Functional classification
Byte4	0x00	Focusing page (page 1)	Page
Byte5	xx	Lens type	Command of option 1
Byte6	xx	Manual focusing speed 1~10	Command of option 2
Byte7		Statistic frame number of automatic focusing 1~15	Command of option 3
Byte8	xx	Automatic focusing speed MAX1~10	Command of option 4
Byte9	xx	Automatic focusing speed MIN1~10	Command of option 5
Byte10~Byte21	0x00	Reserved	

Byte22	0xXX	Checksum	Check bit
Byte23	0xF0	Frame end	Frame end

(2) Defective pixel page

Query response command contents of the defective pixel page are as shown in Table 5-31.

Table 5-31 Commands of defective pixel page

Command word	Byte	Parameter description	Parameter type
Byte0	0x55	Frame header byte 1	Frame header
Byte1	0xAA	Frame header byte 2	
Byte2	0x13	Length is 19	Command length
Byte3	0x03	Application	Functional classification
Byte4	0x01	Defective pixel correction page (page 2)	Page
Byte5	0x00	Cross cursor off	
	0x01	Cross cursor on	
Byte6	xx	Cursor location X[15:8]	
Byte7	xx	Cursor location X[7:0]	
Byte8	xx	Cursor location Y[15:8]	
Byte9	xx	Cursor location Y[7:0]	
Byte10	xx	AD value of cursor point [15:8]	
Byte11	xx	AD value of cursor point	

		[7:0]	
Byte12	xx	Cursor R component	
Byte13	xx	Cursor G component	
Byte14	xx	Cursor B component	
Byte15	0x00	Automatic defective pixel search	Not supported
Byte16	0x00	Automatic defective pixel search threshold [15:8]	Not supported
Byte17	0x00	Automatic defective pixel search threshold [7:0]	Not supported
Byte18	0x00	Automatic defective pixel search number [15:8]	Not supported
Byte19	0x00	Automatic defective pixel search number [7:0]	Not supported
Byte20	xx	Cursor point Y16 [15:8]	
Byte21	xx	Cursor point Y16 [7:0]	
Byte22	0xXX	Checksum	Check bit
Byte23	0xF0	Frame end	Frame end

(3)Menu function page

Not supported

(4)Hot tracking page 1 (regional analysis)

Table 5-32 regional analysis page command

Command word	Bytes	Parameter specification	Parameter type
Byte0	0x55	Frame header byte 1	Frame header
Byte1	0xAA	Frame header byte 2	
Byte2	0x28	Length 40	Command length
Byte3	0x03	Application	Functional classification
Byte4	0x04	regional analysis page (The fourth page)	Page number
Byte5	0x00	Close analysis	Option 1 command
	0x01	Full screen analysis	
	0x02	Region 1	
	0x03	Region 2	
	0x04	Region 3	
Byte6	xx	Upper left corner of regional Coordinate X[15: 8]	Option 2 command
Byte7	xx	Upper left corner of regional Coordinate X[7:0]	
Byte8	xx	Upper left corner of regional Coordinate Y[15: 8]	Option 3 command
Byte9	xx	Upper left corner of regional Coordinate Y[7:0]	
Byte10	xx	Upper left corner of regional Coordinate W[15: 8]	Option 4 command
Byte11	xx	Upper left corner of regional	

		Coordinate W[7:0]	
Byte12	xx	Upper left corner of regional Coordinate H[15: 8]	Option 5 command
Byte13	xx	Upper left corner of regional Coordinate H[7:0]	
Byte14	xx	Region frame color component R	Option 6 command
Byte15	xx	Region frame color component G	Option 7 command
Byte16	xx	Region frame color component B	Option 8 command
Byte17	0x00	High temperature alarm off	Option 9 command
	0x01	High temperature alarm on	
Byte18	xx	High temperature alarm threshold[15: 8]	Option 10 command
Byte19	xx	High temperature alarm threshold[7: 0]	
Byte20	0x00	Temperature does not exceed alarm threshold	
	0x01	Temperature exceeds alarm threshold	
Byte21	xx	The coldest spot coordinate X[15: 8]	
Byte22	xx	The coldest spot coordinate X[7:0]	
Byte23	xx	The coldest spot coordinate Y[15: 8]	

Byte24	xx	The coldest spot coordinate Y[7:0]	
Byte25	xx	The coldest spot temperature/Y16[15: 8]	Observation type 0-65535, Thermography type-50°C -1000°C, Magnify 10 times
Byte26	xx	The coldest spot temperature/Y16[7:0]	
Byte27	xx	The hottest spot coordinate X[15: 8]	
Byte28	xx	The hottest spot coordinate X[7:0]	
Byte29	xx	The hottest spot coordinate Y[15: 8]	
Byte30	xx	The hottest spot coordinate Y[7:0]	
Byte31	xx	The hottest spot temperature/Y16[15: 8]	Observation type 0-65535, Thermography type-50°C -1000°C, Magnify 10 times
Byte32	xx	The hottest spot temperature/Y16[7:0]	
Byte33	xx	Cursor spot coordinate X[15: 8]	
Byte34	xx	Cursor spot coordinate X[7:0]	
Byte35	xx	Cursor spot coordinate Y[15: 8]	
Byte36	xx	Cursor spot coordinate Y[7:0]	
Byte37	xx	Cursor spot temperature/Y16[15: 8]	Observation type 0-65535, Thermography type-50°C

Byte38	xx	Cursor spot temperature/Y16[7:0]	-1000℃, Magnify 10 times
Byte39	xx	Regional average temperature/Y16[15: 8]	Observation type 0-65535, Thermography type-50℃ -1000℃, Magnify 10 times
Byte40	xx	Regional average temperature/Y16[7:0]	
Byte41	0x00	Reserved	
Byte42	0x00	Reserved	
Byte43	0xXX	Checksum	Check bit
Byte44	0xF0	Frame end	Frame end

(5)Hot tracking page 2 (Hot Tracking)

Table 5-33 Hots Tracking page command

Command word	Bytes	Parameter specification	Parameter type
Byte0	0x55	Frame header byte 1	Frame header
Byte1	0xAA	Frame header byte 2	
Byte2	0x13	Length 19	Command length
Byte3	0x03	Application	Functional classification
Byte4	0x05	Hot Tracking page (The fifth page)	Page number
Byte5	0x00	The hottest spot cursor off The hottest spot cursor off	Option 1 command
	0x01	The hottest spot cursor on The hottest spot cursor off	
	0x02	The hottest spot cursor off The hottest spot cursor on	
	0x03	The hottest spot cursor on The hottest spot cursor on	
Byte6	xx	Hot tracking upper limit value[15: 8]	Option 2 command
Byte7	xx	Hot tracking upper limit value[7:0]	

Byte8	xx	Hot tracking lower limit value[15: 8]	Option 3 command
Byte9	xx	Hot tracking lower limit value[7:0]	
Byte10	xx	The hottest cursor spot color component R	
Byte11	xx	The hottest cursor spot color component G	
Byte12	xx	The hottest cursor spot color component B	
Byte13	xx	The coldest cursor spot color component R	
Byte14	xx	The coldest cursor spot color component G	
Byte15	xx	The coldest cursor spot color component B	
Byte16- Byte21	xx	Reserved	
Byte22	0xXX	Checksum	Check byte
Byte23	0XF0	Frame end	Frame end

(6)Hotspot tracking page 3 (Pseudo-color vision enhancement)

Table 5-34 Pseudo-color vision enhancement page command

Command word	Bytes	Parameter specification	Parameter type
Byte0	0x55	Frame header byte 1	Frame header
Byte1	0xAA	Frame header byte 2	
Byte2	0x19	Length 25	Command length
Byte3	0x03	Application	Functional classification
Byte4	0x06	Hot tracking page (The sixth page)	Page number
Byte5	0x00	Pseudo-color band off	Option 1 command
	0x01	Pseudo-color band on	
Byte6	0x00	Pseudo-color vision enhancement manual mode	Option 2 command
	0x01	Pseudo-color vision enhancement semi-automatic mode	
	0x02	Pseudo-color vision enhancement automatic mode	

Byte7	0x00	Reserved		Option 3 command
Byte8	xx	Pseudo-color enhancement threshold [15: 8]	vision upper	Option 4 command Observation type 0-65535, Thermography type-50°C -1000°C, Magnify 10 times
Byte9	xx	Pseudo-color enhancement threshold[7:0]	vision upper	
Byte10	xx	Pseudo-color enhancement threshold[15: 8]	vision lower	Option 5 command Observation type 0-65535, Thermography type-50°C -1000°C, Magnify 10 times
Byte11	xx	Pseudo-color enhancement threshold[7:0]	vision lower	
Byte12	0x00	Isotherm off		Option 6 command
	0x01	Isotherm on		
Byte13	0x00	Upper and lower isotherm display mode		Option 7 command
	0x01	Medium isotherm display mode		
Byte14	xx	Upper limit of isotherm threshold[15:8]		Option 8 command Observation type 0-65535, Thermography type-50°C -1000°C, Magnify 10 times
Byte15	xx	Upper limit of isotherm threshold[7:0]		
Byte16	xx	Lower limit of isotherm threshold[15:8]		Option 9 command Observation type 0-65535, Thermography type-50°C -1000°C, Magnify 10 times
Byte17	xx	Lower limit of isotherm threshold[7:0]		
Byte18	0x00	Reserved		Option 10 command
Byte19	0x00	Reserved		
Byte20	0x00	Reserved		
Byte21	0x00	Reserved		
Byte22	0x00	Reserved		Option 11 command
Byte23	0x00	Reserved		
Byte24	0x00	Reserved		
Byte25	0x00	Reserved		Option 12 command
Byte26	0x00	Reserved		
Byte27	0x00	White heat		
	0x01	fulgurite		Option 13 command
	0x02	iron red		
	0x03	hot iron		
	0x04	medical treatment		

	0x05	arctic	
	0x06	Rainbow 1	
	0x07	Rainbow 2	
	0x08	Trace red	
	0x09	Black heat	
Byte28	0xXX	Checksum	Check byte
Byte29	0xF0	Frame end	Frame end

5.2.2.2.5 Thermography page

(1) Parameter setting page

Query response command contents of the temperature measurement page are as shown in Table 5-35.

Table5-35 Thermography function page 1 command

Command word	Byte	Parameter description	Parameter type
Byte0	0x55	Frame header byte 1	Frame header
Byte1	0xAA	Frame header byte 2	
Byte2	0x19	Length is 25	Command length
Byte3	0x04	Measurement page	Functional classification
Byte4	0x00	Page 1	Page number
Byte5	0-255	The value of distance setting	
Byte6	0-255	The value of emissivity setting	
Byte7	00	Minimum + maximum temperature of current analysis object	
	01	Cross cursor spot+ maximum temperature	

	02	minimum + Cross cursor spot temperature	
Byte8	00	Temperature unit: °C	
	01	Temperature unit: °F	
	02	Temperature unit: °K	
Byte9	0x00	Reserved	
Byte10	0x00	Reserved	
Byte11	xx	Coordinate X [15:8] is based on byte7 value	The parameters(coordinate X, coordinate Y, temperature) of the first point are related to byte7 value: 00 means minimum temp. 01means cross cursor temp. 02 means Minimum temp. (actual temperature*10)
Byte12	xx	Coordinate X [7:0] is based on byte7 value	
Byte13	xx	Coordinate Y [15:8] is based on byte7 value	
Byte14	xx	Coordinate Y [7:0] is based on byte7 value	
Byte15	xx	The temperature[15 : 8] after calibration is based on byte7 value	
Byte16	xx	The temperature[7 : 0] after calibration is based on byte7 value	
Byte17	xx	Coordinate X [15:8] is based on byte7 value	

Byte18	xx	Coordinate X [7:0] is based on byte7 value	coordinate Y, temperature) of the second point are related to byte7 value : 00: Maximum temp. 01: Maximum temp. 02: Cross cursor temp. (actual temperature*10)
Byte19	xx	Coordinate Y [15:8] is based on byte7 value	
Byte20	xx	Coordinate Y [7:0] is based on byte7 value	
Byte21	xx	The temperature[15 : 8] after calibration is based on setting of byte7 value	
Byte22	xx	The temperature[7 : 0] after calibration is based on setting of byte7 value	
Byte23	xx	Reflected temp[15 : 8]	
Byte24	xx	Reflected temp [7 : 0]	
Byte25	xx	Humidity value	
Byte26	xx	Temperature measurement range	
Byte27	0x00	Reserved	
Byte28	0xXX	XOR checkout	Check bit
Byte29	0xF0	Frame end	Frame end

(2) Blackbody correction page

Query response command contents of the blackbody correction page are as shown in Table 5-36.

Table 5-36 Thermography function page 2 command

Command word	Byte	Parameter description	Parameter type
Byte0	0x55	Frame header byte 1	Frame header
Byte1	0xAA	Frame header byte 2	
Byte2	0x19	Length is 25	Command length
Byte3	0x04	Measurement page	Functional classification
Byte4	0x01	Page 2	Page number
Byte5	xx	Low blackbody temperature [15:8]	
Byte6	xx	Low blackbody temperature [7:0]	
Byte7	xx	High blackbody temperature [15:8]	
Byte8	xx	High blackbody temperature [7:0]	
Byte9	xx	Single point blackbody temperature [15:8]	
Byte10	xx	Single point blackbody temperature [7:0]	
Byte11~ Byte27		Reserved	
Byte28	0xFF	XOR checkout	Check bit
Byte29	0xF0	Frame end	Frame end

Remark:

The "highest temperature", "lowest temperature", "central temperature" and "average temperature" mentioned in the above table are "10* actual temperature".

6 Mechanical interface specification

6.1 The structure of N-Driver384

The structure of N-Driver384 is as shown in Fig. 6-1.

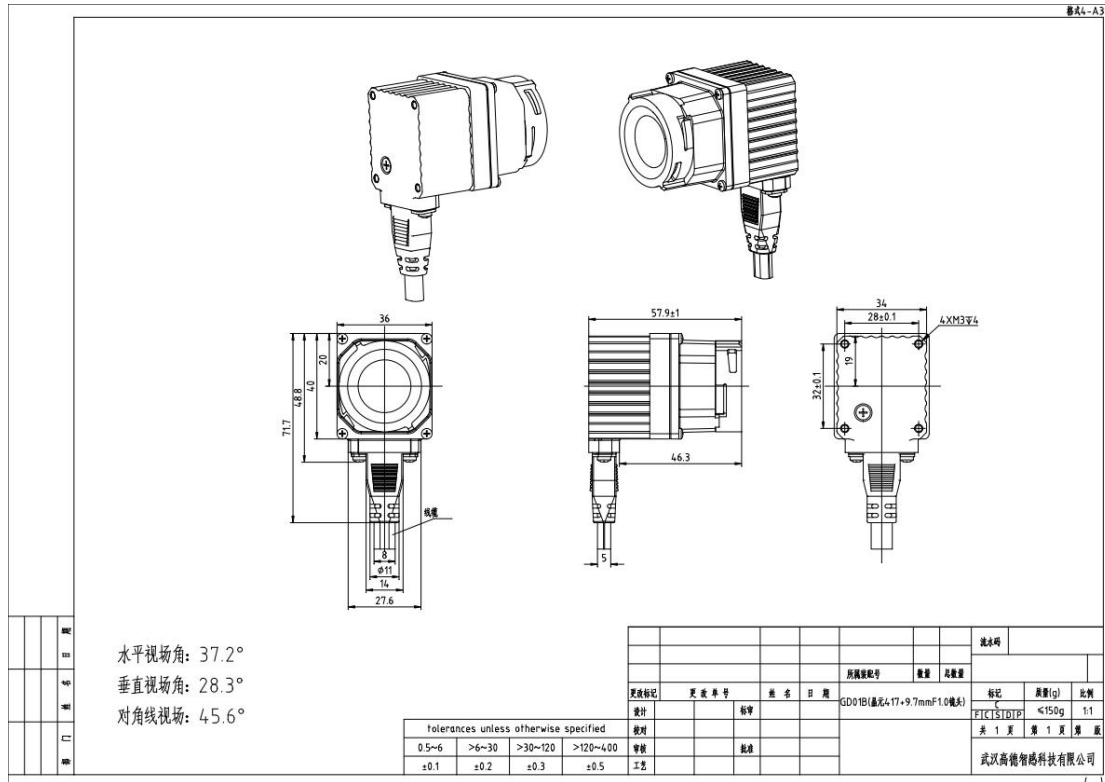

Fig. 6-1 N-Driver384 structure diagram